

Science and Technology English II

Exercise 213 “Presentation” Meiji University 2020

EX_213.pptx 52 Slides August 10th, 2020

<http://mikami.a.la9.jp/mdc/mdc1.htm>

Renji Mikami

Renji_Mikami(at_mark)nifty.com [mikami(at_mark)meiji.ac.jp]

試験について(最終)

- 試験は、Day14 授業中に実施します。回答は和文英文の選択可能です。PC/Smart Phone/Tablet 辞書持込可(単語調べやサイトのビューイングOK)ですが、自動翻訳サイトとメール使用はなし。
- 試験時間は、当日授業内で公表します。(最初にやるかも?)
- 試験開始時間に遅れた場合は、試験を受けられませんので、遅刻しないように注意してください。
- 諸事情に対しては公正に考慮したいと思います。事前にメールしてください。
- その他の質問はありますか？



以下原本を解説します



Giving a good ISSCC presentation

Tips on how to prepare and give a good ISSCC talk

Jan Van der Spiegel

Jeju, Korea - November 13, 2007

©ISSCC



October Meeting: Paper review/selection





Once your paper is accepted ...

- You convinced the Program Committee of the high technical quality of your work.
- **Next:** convince the audience (~3700) of the quality of your work.

ISSCC Attendance

- ISSCC is a highly attended conference:
 - 3,700-3,800 participants

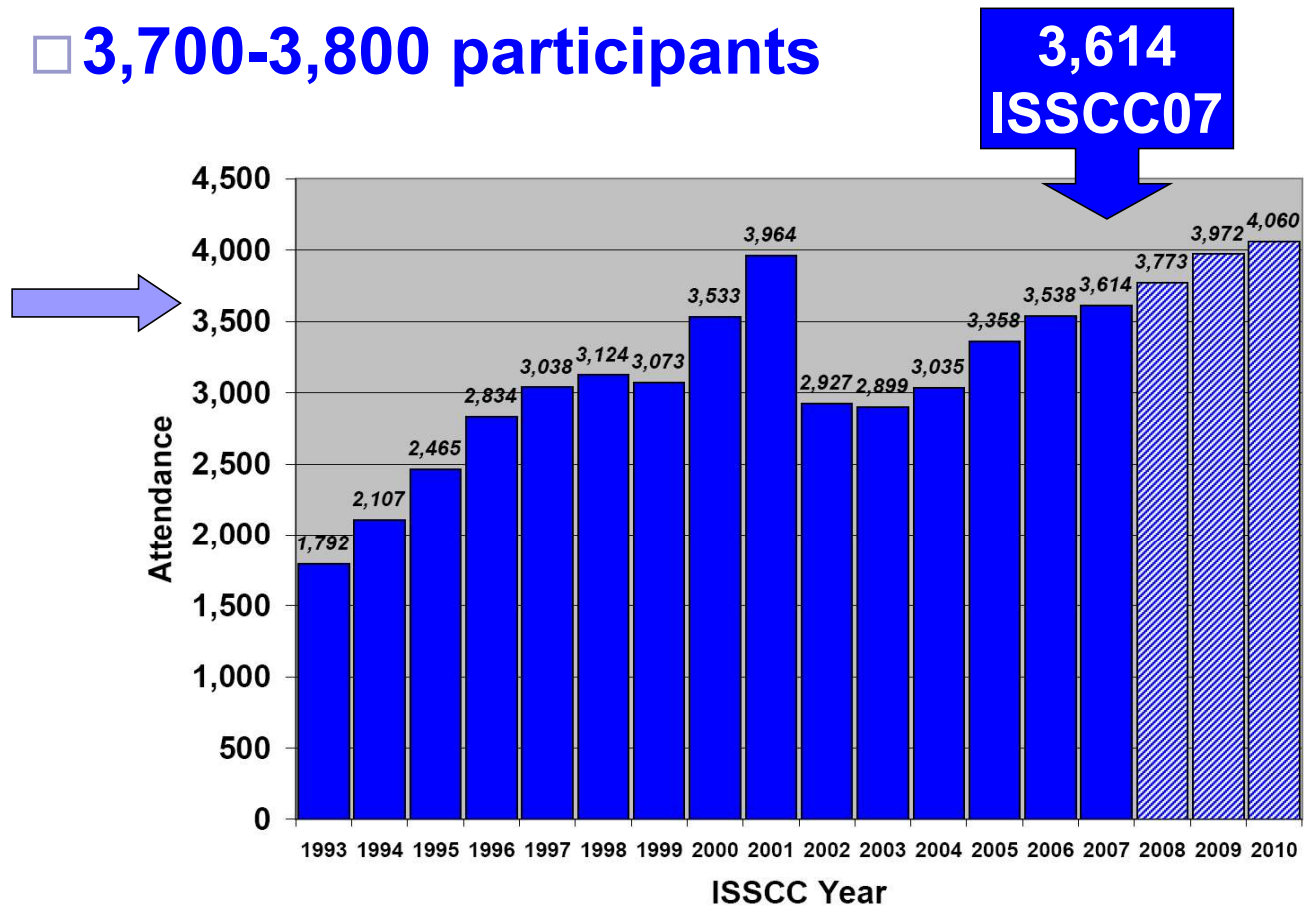

At the conference

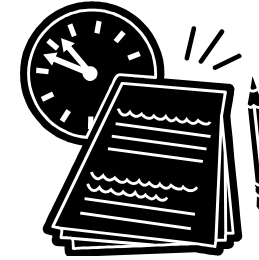

each presentation is evaluated by the audience for

...

- Originality
- Technical contents
- Presentation quality**

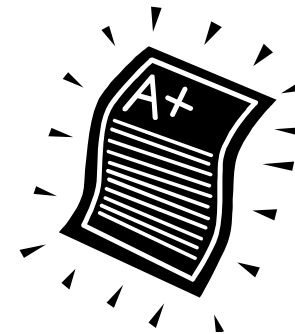

Strong correlation between ratings of the technical quality and presentation

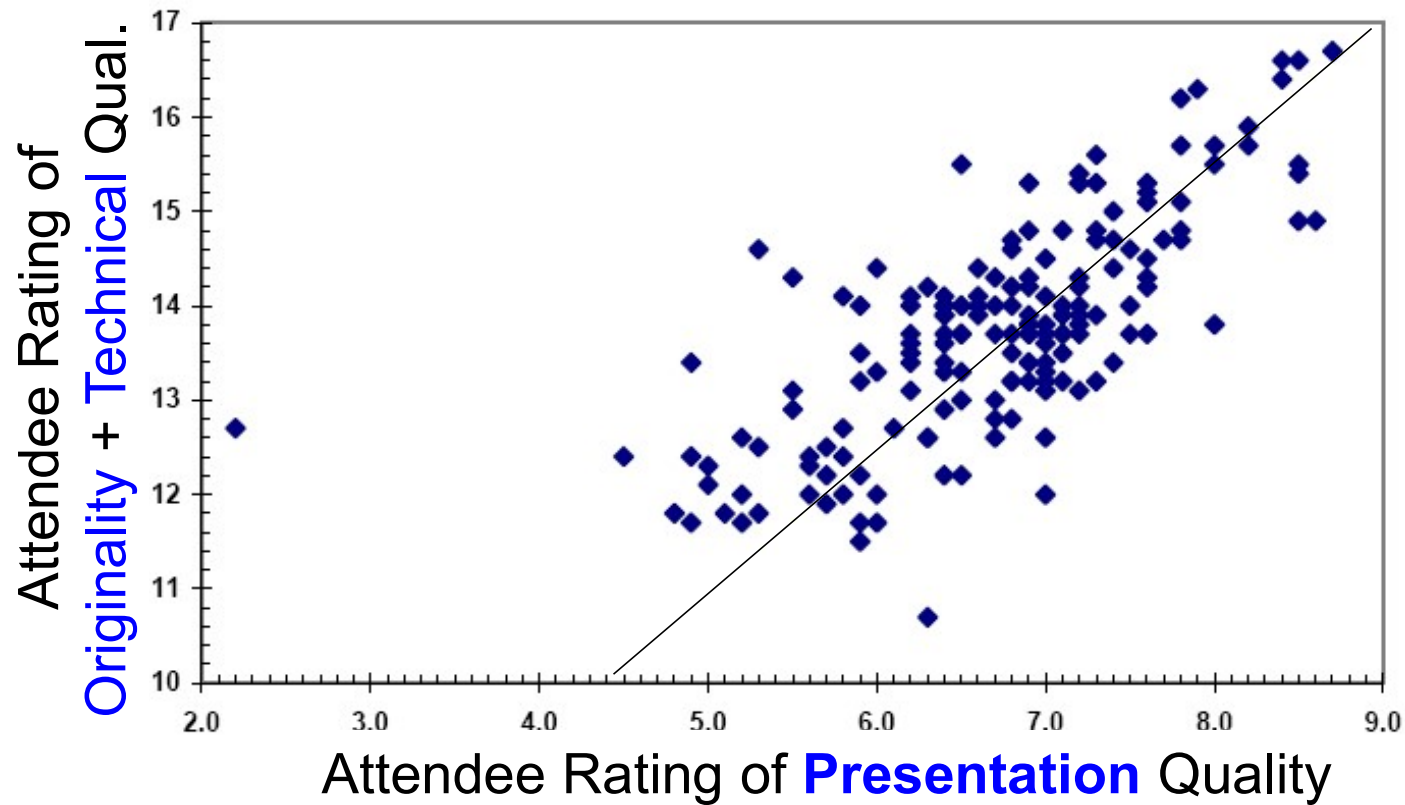

What does the correlation tell?

- A **well-presented and well-organized** paper is perceived as also being of **higher technical quality!**
- Spending time in preparing, organizing and rehearsing the presentation will pay off well.



How do papers from FE compare to the rest?

- ISSCC2007 paper ratings by attendees
(max: 30)

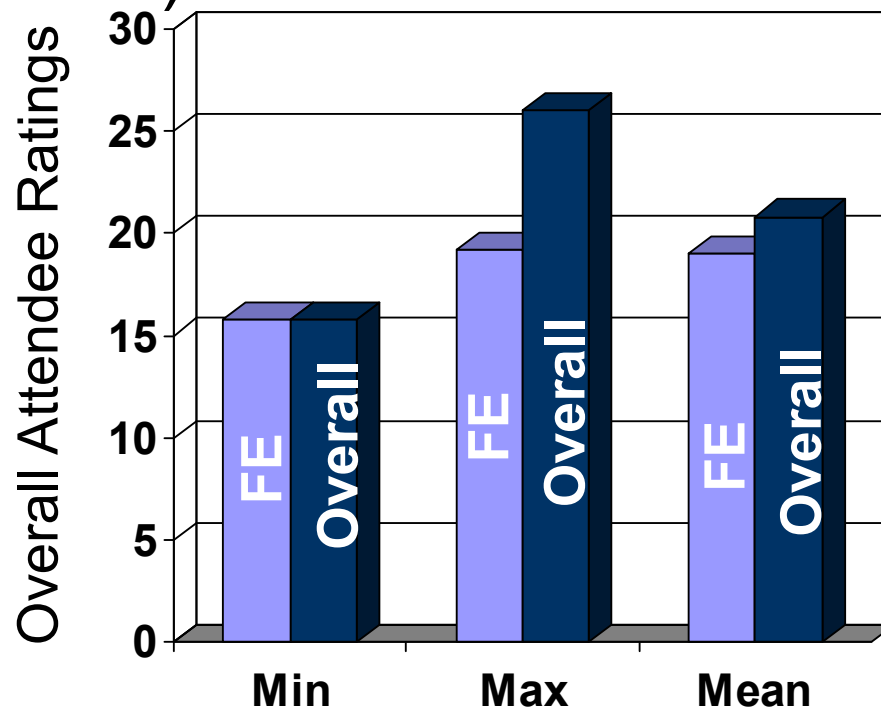

Overview

- Background of the ISSCC:
 - What makes ISSCC unique
 - Quality of papers and presentations
 - Importance of a good presentation
- Key aspects of a successful presentation:
 - Contents
 - Visuals
 - Actual presentation
- Summary

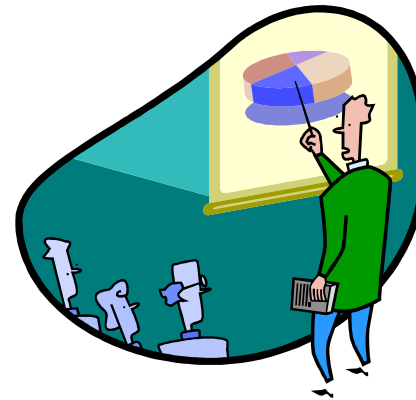

Before you begin writing the presentation, ask yourself:



- What problem does my paper solve ?
- What results do I want to communicate ?
- How does my work improve on previously published work ?
- What are the key results ?

Typical outline and contents

- Slide with outline of the talk
- Background and motivation
- Proposed solution to the problem
- Architecture and circuits
- Experimental results
- Chip photograph
- Summary in the form of a table
- Discussion and conclusion





Introducing the topic

- **Background and Motivation:**
- What is the problem you have solved?
 - Why is this important (motivation)?
 - Discuss the state-of-the-art in terms of what others have done recently.
 - Capture the different approaches to solving the problem and show which of these approaches you have picked and why.
 - Continue with explaining your approach ...

Why 60 GHz?

- **7 GHz of Unlicensed Band**
- **Possibility of Realizing (Multiple) On-Chip Antennas:**
 - **Low-Cost Packaging**
 - **Beamforming**
 - **Differential Operation → Higher Output Power**
 - **No Need for T/R Switch**
 - **No Need for AC Coupling**
 - **No Need for High-Frequency ESD Devices**
- **Possible Applications:**
 - **Gb/s Networks, e.g., HD Video Streaming**
 - **Laptops Simplified to Dumb Terminals**

Ambient intelligence

- Electronics integrated in “every day life”:
adaptable, responsive and invisible technology

- The connected house
- Wearable electronics
- The portable office

- **Building blocks**

- Displays
- Sensors and actuators
- Wireless connectivity
- Energy supply



- **Contactless identification transponders**

Contactless RFID transponders

- State-of-the-art examples:
 - Car keys
 - Animal identification
 - Subway, bus tickets
 - Turnpikes
- Future smart labels or “electronic barcodes”
 - libraries, supermarket
 - drug identification, luggage, kiwi’s, tennis balls, flowers, ...
- **Crucial : ultra low cost and high volume**



© 2006 IEEE International Solid-State Circuits Conference © 2006 IEEE



Explaining your approach ...

- This should focus on the **main contribution**:
 - Show a figure or diagram to show your approach.
 - Preferably, show circuit schematics
 - Explain clearly and concisely how the circuit works and what is new about it.

Organic RFID transponders

Road blocks towards introduction of large scale RFID technology (wholesale, retail, etc.)

- Too high cost:
 - RFID chip ← Organic electronics
 - Antenna
 - Antenna/chip assembly ← Printed electronics
- Need for enormous production throughput and integration onto the package

Receiver Architecture

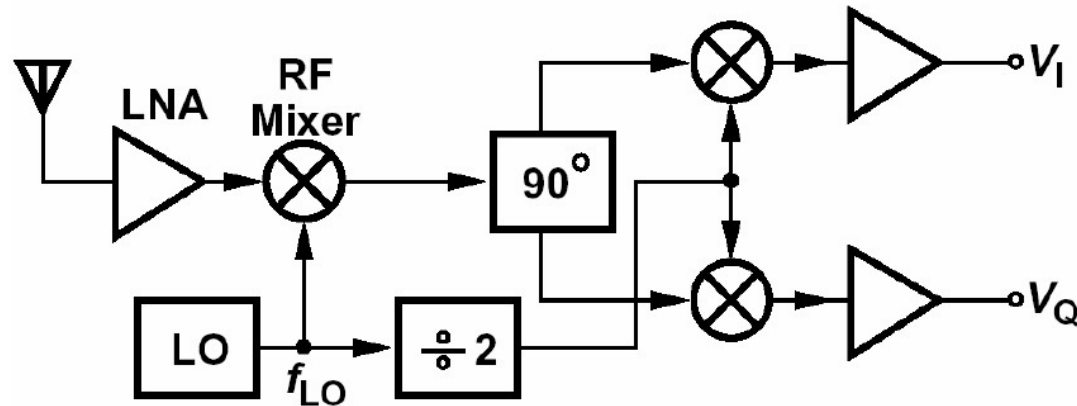

- LO operates at 40 GHz and need not provide quadrature outputs.
- Choice of $\div 2$ over $\div 4$ governed by image rejection.
- LO not pulled by interferers.
- Divider easier to design, but not that easy \rightarrow quadrature separation in current domain.

© 2007 IEEE International Solid-State Circuits Conference © 2007 IEEE

Mixer Candidates

Conventional Mixer

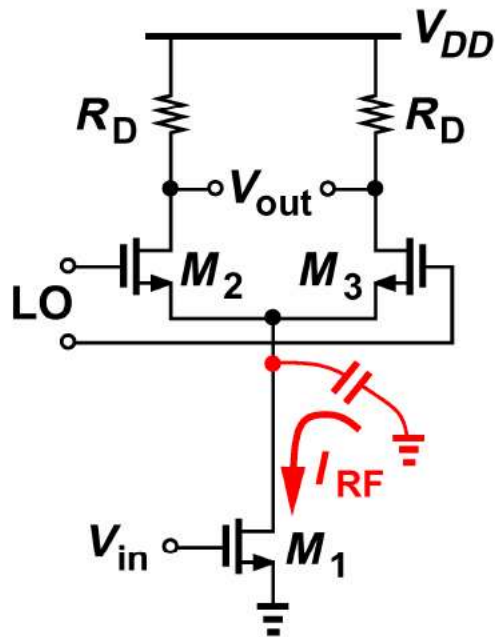

NF = 26 dB
Conversion Gain = 0 dB

Proposed Mixer

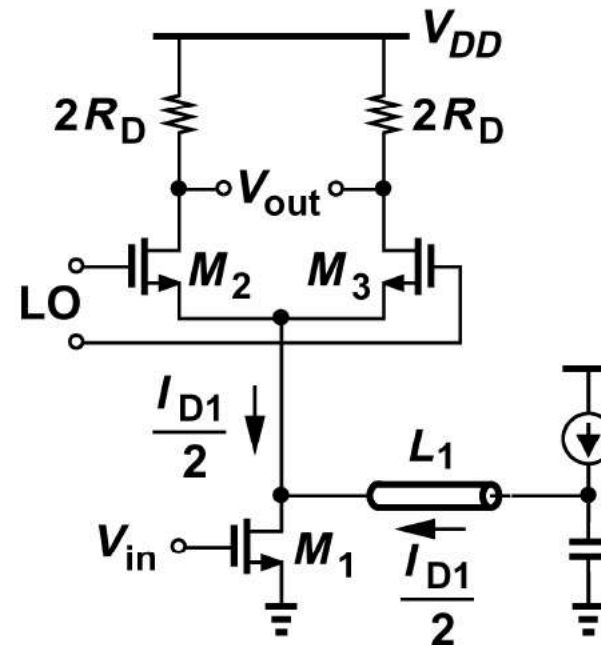

NF = 17 dB
Conversion Gain = 12 dB
[Razavi, JSSC, Jan. 06]

© 2007 IEEE International Solid-State Circuits Conference © 2007 IEEE

Mixer Design

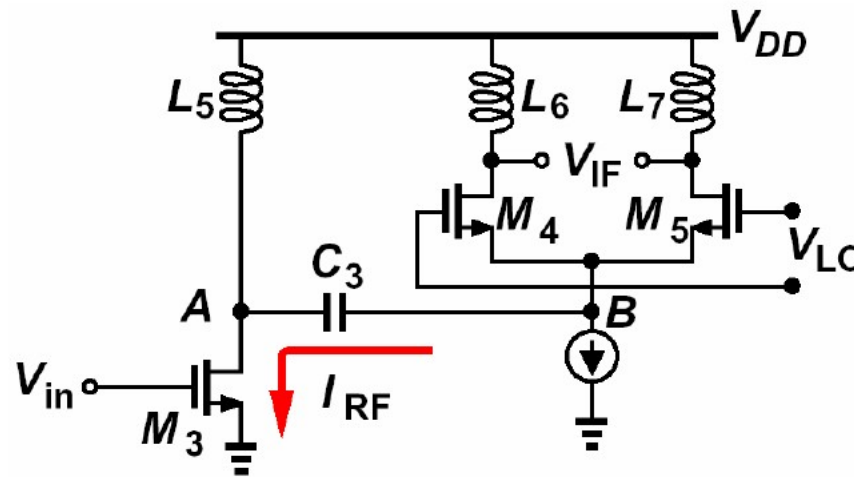



[Razavi, VLSI Symp. 97]

- L_6 and L_7 suppress LO feedthrough.

© 2007 IEEE International Solid-State Circuits Conference © 2007 IEEE

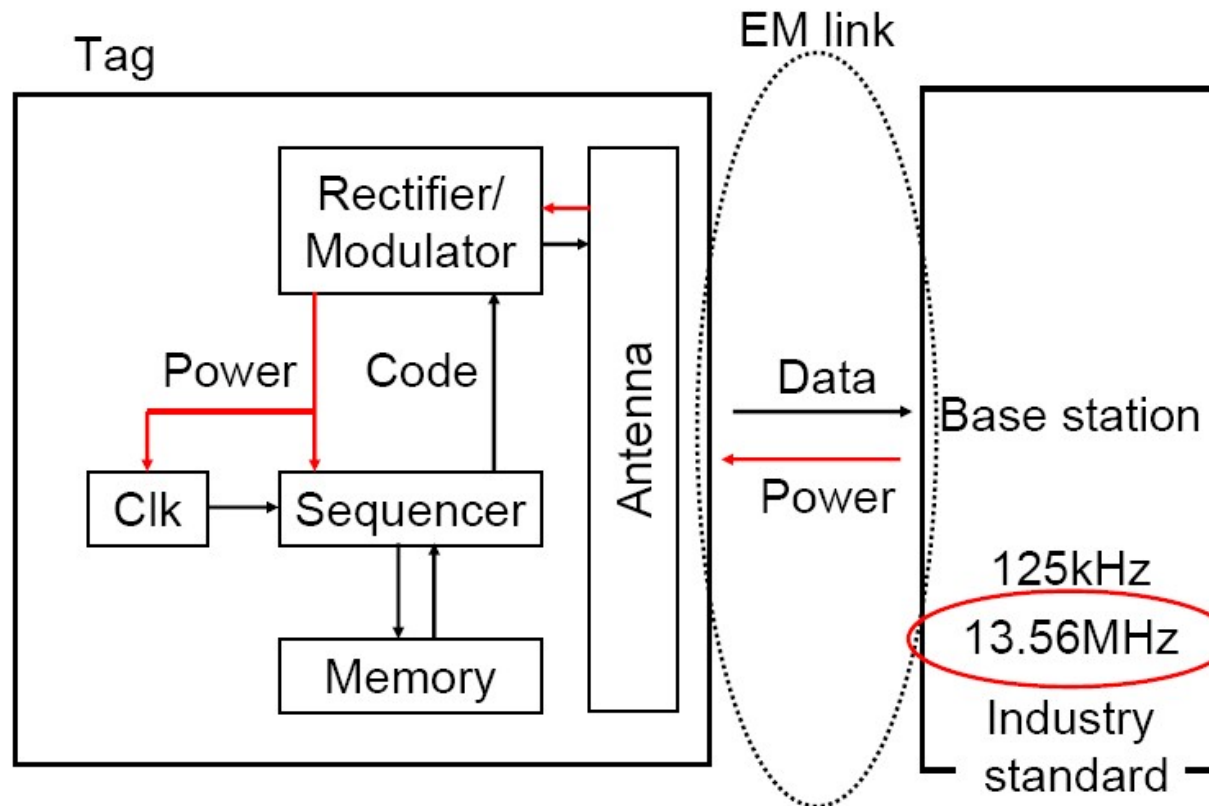
Block diagram of a RFID system





Don't try to give too much
information on one slide:
Example

Pipeline Stage Optimization (1/2)

1) Sampling capacitors (C_S) for a given scaling factor (f_s)

10b ADC
n-bit MDAC

M (# of MDAC stage) = $\lceil 9/(n-1) \rceil - 1$

$$N_{tot} = N_{S/H} + N_{MAC1} + \frac{N_{MAC2}}{(2^{2(n-1)})^1} + \dots + \frac{N_{MACM}}{(2^{2(n-1)})^{M-1}}$$

$$= N_{S/H} \left[2 + \sum_{i=1}^{M-1} \frac{1}{(4^{n-1} \cdot f_s)^i} \right] < N_q \left(= \frac{1}{(2^{10})^2 \times 12} \right)$$

2) Transconductances (g_{m1} , g_{m2} , and g_{m3})

Single stage	$g_{m1} \cong \frac{C_L \cdot (N - n + 1) \cdot \ln 2}{\beta \cdot t}, \quad \beta = \frac{C_L}{C_C + C_F + C_{in}}$	
Two stage	$g_{m1} \cong \frac{C_C \cdot (N - n + 1) \cdot \ln 2}{\beta \cdot t}$ $g_{m2} \cong \frac{2C_L \cdot (N - n + 1) \cdot \ln 2}{t}$	
Three stage	$g_{m1} \cong \frac{C_C \cdot (N - n + 1) \cdot \ln 2}{\beta \cdot t}$ $g_{m2,3} \cong \frac{2.7C_L \cdot (N - n + 1) \cdot \ln 2}{t}$ $\left\{ \begin{array}{l} C_L \cong 3C_C \\ S_0 = \sqrt{\frac{C_{m2}C_L}{4C_{m1}^2}} = 1 \end{array} \right.$	

$$C_L \cong f_s C_S + C_{out} + (2^n - 2)C_{pre} + \frac{C_F (C_S + C_{in})}{C_F + C_S + C_{in}}$$



Giving measurement results

- **Measurement of the fabricated chip:**
 - Explain briefly **what** you measured and **how**.
 - Indicate what has been included or excluded.
 - Use graphs to show the results and explain what is shown; measured vs. simulated.
 - If appropriate, provide a Figure-of-Merit to prove that your work advances the state-of-the-art.
 - Include a summary table of the design that highlights the specification and performance metrics.

Measured NF and Gain

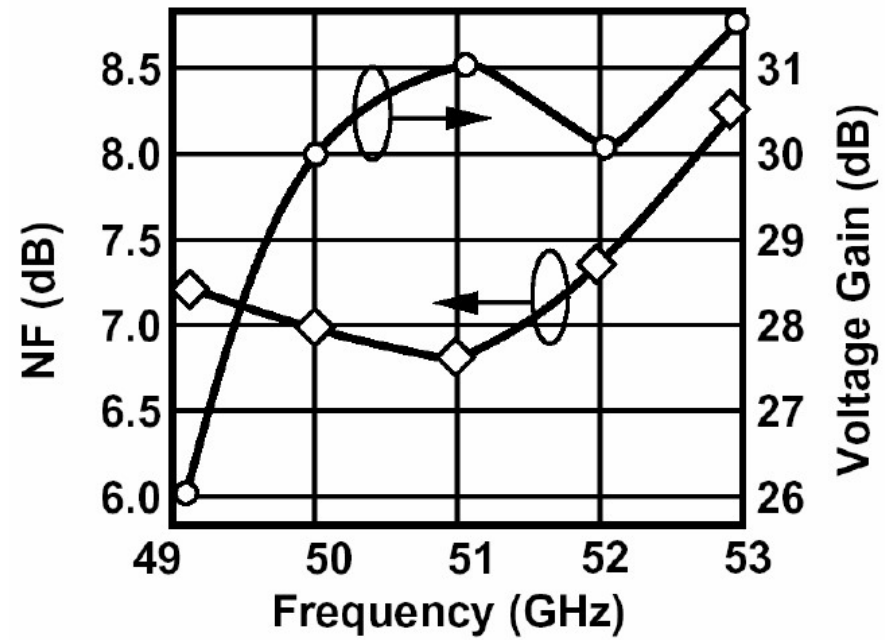

Rectifier performance

- Rectifier output voltage vs. V_{ACpp} and carrier frequency

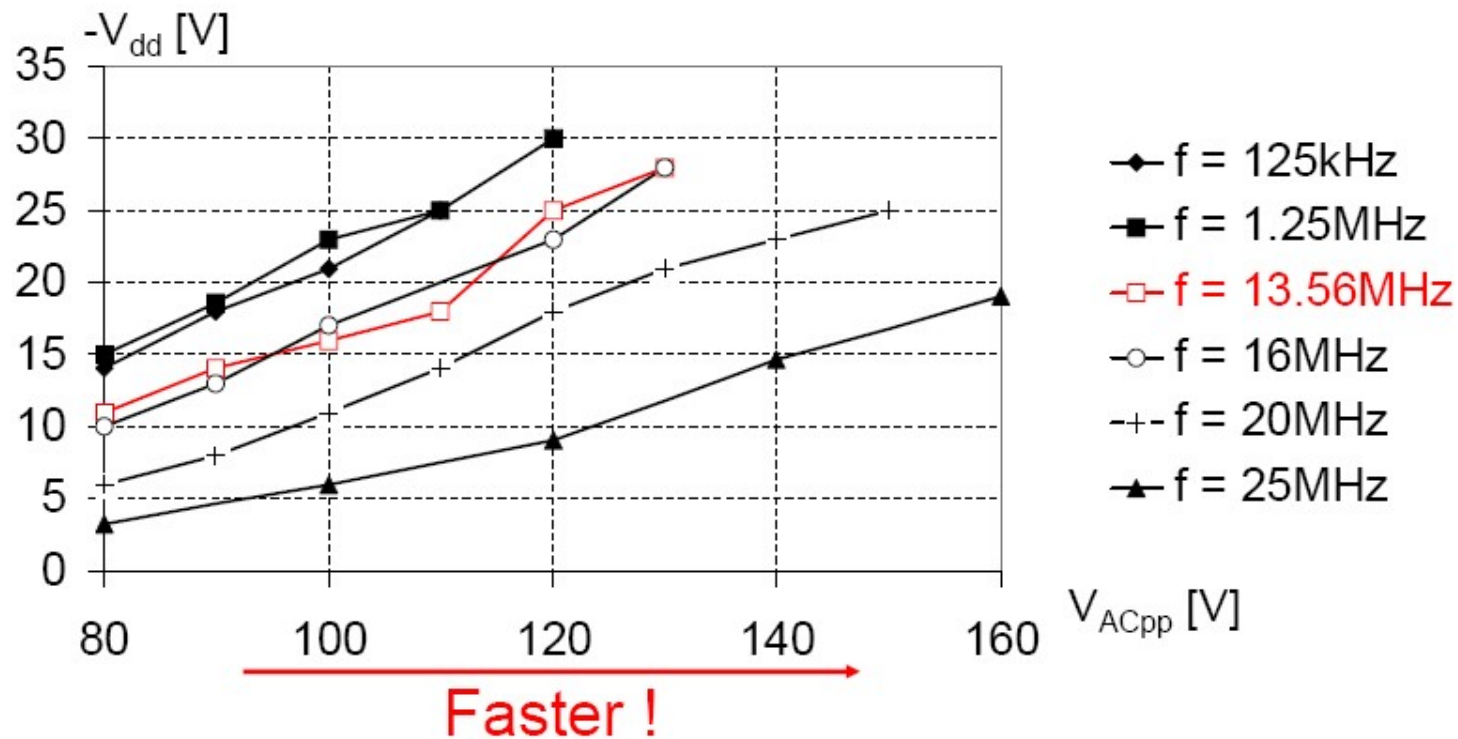



Comparing your results

- If appropriate, compare your results with those of others:
 - Be straightforward in the comparison.
 - Compare measured results against stated requirements, and to prior art.
 - Do not ignore bad results; discuss and explain any shortcomings, rather than ignoring them.
 - Use a graph or table to compare your results with others. Preferably, compare to a previous ISSCC papers.

Comparison with SiGe

	Receiver in [6]	This Work
Noise Figure	5–6.7 dB	6.9–8.3 dB
Voltage Gain	38–40 dB	26–31.5 dB
1-dB Compression Point	–36 dBm	–25.5 dBm
LO Leakage to Input	NA	–47 dBm
Image Rejection ratio	30 dB	44.5 dB
I/Q Mismatch	1 dB/4°	1.6 dB/6.5°
LO Phase Noise @ 1-MHz Offset	–90 dBc/Hz	–95 dBc/Hz
Power Dissipation	450 mW *	80 mW
Supply Voltage	2.7 V	1.8 V
Technology	200-GHz BiCMOS	90-nm CMOS

[6] Floyd et al, ISSCC 06.

B. Razavi, Paper 10.1, ISSCC07

Benchmarking

	Frequency	Code length	Rectifier
This paper	13.56MHz	6b and 64b	lateral
Baude et al., DRC 2004	1.2MHz	8b	none
Rotzoll et al., MRS 2005	13.56 MHz	none	lateral
Steudel et al., Nature Mat. 2005	50MHz	none	vertical

Reaching the finish line:



■ Discussing and summarizing the talk:

- The final or pre-final slide should:
 - Summarize all important measured results
 - Give the audience a complete picture of your system
 - Convince them of the technical accuracy of your results
- Be quantitative: use numerical data and comparisons to others.

Photo finish ...

- Include a die photo
- Indicate the main blocks (use an overlay)
- Give the chip size
- Mention the technology used

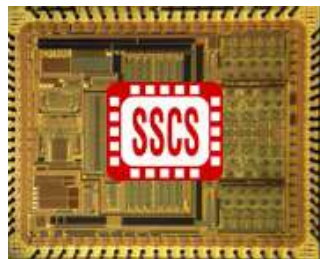

Die Photo with overlays

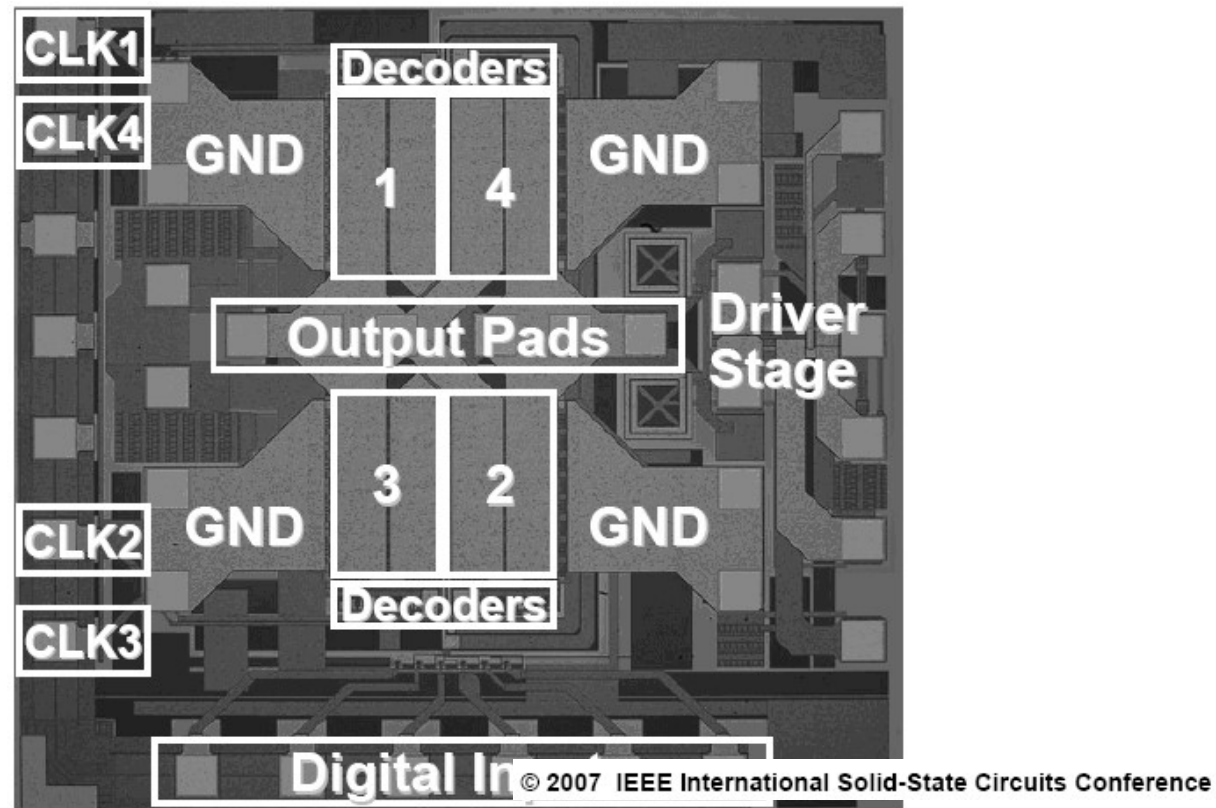

1.3x1.4mm² in 0.18μm CMOS

(Source: A. Kavousian, D. Su, B. Wooley, paper 4.1 in ISSCC 2007)



Overview

- Background of the ISSCC:
 - What makes ISSCC unique
 - Quality of papers and presentations
 - Importance of a good presentation
- Key aspects of a successful presentation:
 - Contents
 - **Visuals**
 - Actual presentation
- Summary

Guidelines for the visuals



Visuals: Do not



- Use company logos
- Mention company names (except in the title slide)
- Advertise or market a product
- Show anything except technical facts and results
- No borders around the slides



Slide guidelines

- Use **Arial** font: (not **Times Roman**)
 - Equal line width
 - Visually simple characters
 - Projects clearly



Font size (titles: 36-44)

- Sub-titles: 36 points
 - Major bullets: 28 points
 - 24 points for indented bullets and text (including on illustrations, overlays on chip photographs).
 - Don't use fonts smaller than 22

- Keep the slides simple:
 - better to use two slides than one slide.



Use of color

- Background: should be white
- Use black text
- Use of color:
 - to highlight parts of the text
 - for graphs and illustrations
- Use deep, bright colors: **red**, **blue**, **green** and **orange** (preferably in bold)
- Do not use pastel colors: **yellow** (=yellow), pink, light blue, etc.



Other practical tips

- Format of the presentation:
 - Microsoft Powerpoint (preferred format)
 - Lotus Freelance
 - Framemaker
 - PDF Acrobat

Overview

- Background of the ISSCC:
 - What makes ISSCC unique
 - Quality of papers and presentations
 - Importance of a good presentation
- Key aspects of a successful presentation:
 - Contents
 - Visuals
 - **Actual delivery of the paper**
- Summary



Tips for a good presentation



■ Prepare the talk carefully:

- Write down the key points you like to say, slide by slide.
- Rehearse many times, until you don't need the text.
- Use keywords to remind you what to say.
- Do not read your text during the presentation.
- Have the text ready in case you need it (depends on your experience and how comfortable you are).

More tips for a good presentation

- Talk slowly and show enthusiasm.
- Practice, practice, practice...and practice.



- Attend the speakers' rehearsals:
 - Regional rehearsal
 - At ISSCC: Saturday before the conference (even the plenary speakers rehearse!)

Other tips for a good presentation

- Don't go over time – **EVER:**
 - A typical ISSCC presentation lasts **25 minutes** and **5 minutes** for questions and answers
 - Short papers: 12 minutes presentation and 3 minutes for questions.



Tips for a good presentation

■ Timing:

- Title page: very short (0.5 min)
- Overview slide: just say a few sentences to summarize the outline (0.5-1 min)
- Conclusion: summarize the main contributions and achievements.

- Total no. of slides: about 15 (~1.5-2 min per slide)





Answering Questions:

■ Questions:

- Repeat the questions, if the chairman does not do it.
- For hard questions, you can refer to the authors interview session.
- If you are not sure about the answer, say so; better to say “*I don't have the answer right now*” than to try to come up with an answer.
- Translators will be available if needed.



Overview

- Background of the ISSCC:
 - What makes ISSCC unique
 - Quality of papers and presentations
 - Importance of a good presentation
- Key aspects of a successful presentation:
 - Contents
 - Visuals
 - Actual presentation
- **Summary**

In Summary



- The fact that your paper has been accepted means the technical quality is high.
- Challenge is to convey this to the audience.
- It is all about:
 - Preparation
 - Presentation
 - Practice ...

補足説明

- 2014年 STAP細胞論文問題
- コピペ(COPY&PASTE)しない
- 米国ではコピペを検出するソフト常識
- 引用部分は参考文献を明示する
- 写真の合成・切り貼りしない(2つ画像の比較のためなら説明を明示)
- 別な論文や学会にデータ使い回ししない

Exercise: EX_213

- Writing a good ISSCC presentation プレゼンテーション全文を読んで以下の課題について和文でまとめてください
- EX_213-1 プレゼンテーションのポイントをまとめてください
- EX_213-2 プレゼンテーション上で、してはいけないことをまとめてください
- EX_213-3 プレゼンテーション資料で使用してはいけないと述べているフォントは何でしょうか?その理由を自由に考えて書いてみてください
- 提出はClass Web Report水曜まで

Material Reference:
Engineering English 2, 2018 Meiji
University Masaki. Hirata, Pd.D

Memo

フォローアップURL (Revised)

<http://mikami.a.la9.jp/meiji/MEIJI.htm>

担当講師

三上廉司(みかみれんじ)

Renji_Mikami(at_mark)nifty.com

mikami(at_mark)meiji.ac.jp (Alternative)

http://mikami.a.la9.jp/_edu.htm

